

FOUR X DL



FOURX

www.moventuras.com



OWNER'S MANUAL

Read the manual carefully.
In matters that are unclear, we request that you contact us

Moventuras Oy
Laajalahdentie 23
00330 Helsinki
+358407463340



ISO 7176/19 Wheelchair

Valued CW4 FOUR X DL user,

We welcome you among CW4 FOUR X DL users. We appreciate your confidence in us and we are convinced that your recently received electric wheelchair will fulfil your expectations. The most important aims in the planning and manufacture of the CW4 FOUR X DL are to offer the freedom to move for every person and thus improve their quality of life. Your CW4 FOUR X DL electric wheelchair guarantees you a smooth ride both on and off-road. Now there's no need to plan your route according to where your wheelchair can get, but you can now go wherever you wish. The CW4 FOUR X DL goes agilely up and downhill and climbs up street kerbs easily. Snow, mud or tree roots are no longer obstacles for you.

By paying attention to our user's manual, you will learn how to use the CW4 FOUR X DL electric wheelchair safely for your long-term benefit.

We wish you pleasant riding on the CW4 FOUR X DL.

WARRANTY

Moventuras Oy guarantees a two (2) year warranty for the MOVENTURAS CW4 FOUR X DL electric wheelchair's frame and chassis, the driving control system, driving motors, and the seat. Batteries and charging appliances are not included in the warranty. On every wheelchair there is a model plate which shows a unique serial number.

This warranty covers faults that occur in normal operation of the wheelchair. The warranty does not cover faults caused by normal wear and improper or lack of maintenance as indicated in the owner's manual and the service instructions.

Furthermore, the warranty does not cover faults originating from overloading or incorrect programming. Normal wear occurs in parts such as tyres, rubber mountings, leaf springs, joints and slide surfaces. Increased noise of the driving motors is also caused by normal wear. Indirect expenses incurred in dealing with faults are not included in the warranty.

Wheelchair frame number: _____

Date and signature: _____

DECLARATION OF CONFORMITY



The manufacturer:
Moventuras Oy
Laajalahdentie 23
00330 Helsinki
Finland

declares that the MOVENTURAS CW4 FOUR X DL (Basic UDI: 64300790200020GL) electrically powered wheelchair conforms to the following standard requirements

93/42/EEC
EN 12184

Helsinki 4.1.2021



Janne Pesonen
Managing Director

CONTENTS

1 SAFETY RECOMMENDATIONS.....	6
APPLICABILITY FOR DIFFERENT TYPE OF USERS.....	6
SAFE DRIVING.....	6
SAFE USE AND SERVICE.....	8
2 EQUIPMENT AND THEIR USE.....	11
2.1 DRIVING CONTROLLER USE	11
2.2 BACK REST, HEAD SUPPORT, ARM REST AND FOOT REST ADJUSTMENTS	17
BACK REST ADJUSTMENT	17
MANUALLY ADJUSTABLE BACK REST.....	17
ELECTRICALLY ADJUSTABLE BACK REST	17
HEAD SUPPORT ADJUSTMENT	18
ARM REST ADJUSTMENT.....	18
ADJUSTMENT OF A MANUALLY ADJUSTABLE FOOT REST.....	20
ADJUSTMENT OF AN ELECTRICALLY ADJUSTABLE FOOT REST WITH LENGHT COMPENSATION	20
2.3 OTHER DEVICES AND SUPPLIES	21
SEAT BELT USE.....	21
TYRES.....	21
BATTERIES.....	21
BATTERY RECHARGING.....	21
FUSES	22
3 DRIVING THE WHEELCHAIR.....	23
MOUNTING TO AND FROM THE WHEELCHAIR.....	23
DRIVE PRACTICE	24
BALANCE ADJUSTMENT.....	25
CLIMBING STEPS.....	26
4 FREEWHEELING	27
5 TRANSPORTATION AND PACKAGING OF THE WHEELCHAIR.....	27
6 WHEELCHAIR SERVICING.....	28
DAILY INSPECTIONS.....	28
WEEKLY INSPECTIONS.....	29
CLEANING AND DISINFECTION THE WHEELCHAIR	29
MEASURING THE TYRE AIR PRESSURE.....	29
TYRE EXCHANGE	30
DISCONNECTING THE BATTERIES.....	30
INSTALLING THE BATTERIES.....	30
DRIVING LIGHTS AND INDICATORS.....	31
SPARE PART INFORMATION.....	31
ELECTRIC MALFUNCTION	32
PROGRAMMING.....	32
RE-USE AND RECYCLING	32
7 WHEELCHAIR STORAGE.....	33
8 USE OF THE WHEELCHAIR AS A SEAT IN A VEHICLE.....	33
9 TECHNICAL INFORMATION CW4 FOUR X DL.....	36
10 SERVICE CARD OF FOUR X DL WHEELCHAIR	37

1 SAFETY RECOMMENDATIONS

Read this manual carefully before using the wheelchair. It will guide you on flexible and safe use of the wheelchair and advise you on the procedures for problem situations. Please contact the supplier if you have any further questions.

FourX DL is class 1 medical device. The wheelchair is intended for outdoor use, where it can cross obstacles in normal outdoor conditions and drive on uneven ground. The wheelchair can also be used in suitable indoor premises.

APPLICABILITY FOR DIFFERENT TYPE OF USERS

Wheelchair is intended for person who has active life with the family. Wheelchair is also suitable for persons who want to move and act independently both in the city and in the countryside.

The wheelchair is intended for users weighing not more than 125kg and having the ability to learn the correct use of the equipment and the physical preconditions for using the controlling system and the necessary equipment.

Wheelchair is perfectly suitable for persons whose injury / disease demands soft drive and stability of the seat (there is special flexible chassis structure in the wheelchair). Wheelchair is suitable for instance for accident patients, multiple sclerosis patients, brain infarct patients, overweight persons and arthropathy patients.

Wheelchair is not suitable for visually disabled / blind person; badly spastic person whose moves are so uncontrollable that controlling the wheelchair is impossible; disabled person who is not able to understand the correct function of the wheelchair or he doesn't have the physical preconditions for using the wheelchair; person whose weight cross the maximum user weight. These features which limit the wheelchair use can be a risk both to the wheelchair user and to the person around and to the other environment. Risks can be, among others, losing the control of the wheelchair (falling down, crashing) when the wheelchair user and persons nearby are exposed to danger; damaging of the wheelchair structure when using features and safety of the wheelchair weaken.

Risks mentioned above can be prevent by installing the assistant control system into the wheelchair when controlling and driving of the wheelchair are happening by assistant and then user is not able to use the control system of the wheelchair.

SAFE DRIVING

Do not use the wheelchair if you suspect that the use would not be safe. For safety, take notice of the wheelchair's condition, function and noises, environmental conditions and the users' ability to control the wheelchair. Check the wheelchair's condition weekly at the very least.

The wheelchair has moving parts, such as the wheels, rods and joints. Take note of the dangers your wheelchair may cause especially in the presence of children and pets. Make

sure they remain at a safe distance from the wheelchair. The places that are especially dangerous are marked with these symbols:



Avoid loose clothing or jewellery, which can become entangled in the moving parts.

If you are aware of a fault in the driving controller or any other critical part, do not drive the wheelchair but deliver it immediately for service.

Brake releases must be returned to the DRIVE – position (D) after pushing or towing.

Using the chair on sloped surfaces can be dangerous if the brakes are released.

The wheelchair has four wheel drive and steering. Mastering the driving technique requires practice. Avoid places where a loss of wheel grip can be dangerous, for example wet, sloping lawns.

The wheelchair has a balance adjustment system for improving driving safety and the overcoming of obstacles. It is necessary to learn its correct use. Always check before driving that the seat is in the correct position. Look at the section "Balance adjustment".

Instability can arise when driving on slope if the balance is adjusted incorrectly. Adjusting the balance on a sloped surface requires special caution.

The hill climbing capacity of the wheelchair is greater than the maximum safe driving declination. Driving on a steeper ground than a slope of 10°, which is equivalent to a climb of one meter over five meters, may be dangerous. Also, level differences greater than 100mm can be dangerous (see the pictures below).

Always use low driving speed and avoid extreme steering movements when driving on a slope or uneven surface. At no time it is permitted to use battery box top cover located at the rear of the wheelchair as a seat or for carrying large heavy items. If used for this purpose the warranty of the chair is void.

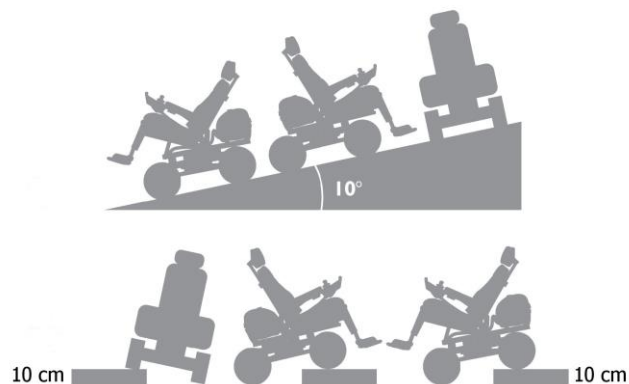

Driving in water is forbidden due to the danger of damaging the wheelchairs electric parts.

Always use lights in the twilight and dark in order to see any obstacles and dangers in your driving path. It is also important that the other road users can see you.

Releasing the joystick stops the chair. In emergency situations the wheelchair can also be stopped by switching off the driving controller.

Take note of the battery charge level before and while driving. Always recharge the batteries when possible. The wheelchair's standard charging equipment will not overcharge the batteries.

The wheelchair operations may be disturbed in electromagnetic fields, which may be emitted by e.g. mobile phones or other similarly emitting equipment. The wheelchair itself can disturb equipment based on electromagnetic fields, such as shop alarm systems.

Don't leave the wheelchair under the straight sun light. Metal parts and surfaces of the wheelchair for example the seat and the cushions of the armrests might heat easily. Also avoid leaving the wheelchair under high freeze.

After driving under moisture circumstances, take care of drying the wheelchair for example by storing it in a warm space. Do not leave the wheelchair outside or in cold and moisture spaces. Not following these instructions might damage the wheelchair.

SAFE USE AND SERVICE

The wheelchair's driving controller has factory settings, which are suitable for most users. It is possible to change some of these settings. Programming should only be performed by healthcare professionals with adequate knowledge of the controller system. Incorrect programming can create dangerous driving properties or damage the controller system.

The reliability of the wheelchair and the control system is improved, if you keep exposure to extreme conditions to a minimum.

Damaged wheelchair cables create a safety risk.

Check the condition of the tyres regularly. It is important for the steering properties and grip abilities to have a correct tyre pressure. Measuring the tyre pressure is explained in section "Wheelchair servicing".

Use the locking key to prevent illicit use of the wheelchair. Someone other than the owner using the wheelchair is a safety risk.

Always attach the wheelchair to the car's chassis part during transport. There are four fixing points on each corner of wheelchair. Sitting in the wheelchair during transportation is absolutely forbidden without the use of the correct 3 point seatbelt attached fitted in the vehicle.

Unauthorized repairs and modifications are forbidden. The user may perform the servicing operations referred to in section "wheelchair servicing". When the wheelchair is being serviced or adjusted, the driving controller must be switched off.

Using the other than gel batteries is forbidden due to the danger of damaging the wheelchair's electric parts.

Handling tools in close proximity to the batteries may cause short circuit. Handling an open flame is forbidden because of the danger of major serious damage. The battery casing is not intended to be used as a storage container. The cables in the battery naves should not disconnect on one's own. In the problem situation, please contact the service.

In case of safety hazard caused by wheelchair, contact wheelchair manufacturer and local authorities.

THE PERMANENT LABELLING OF THE WHEELCHAIR

Identification plates, situated on the left side of the frame

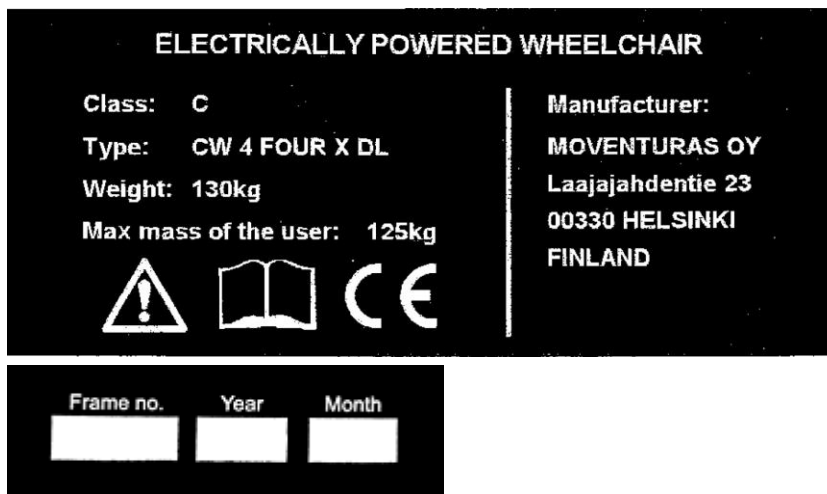

Wheelchair classification
Maximum safe slope 10°

Highest safe obstacle negotiation ability
100mm

General driving restriction

Located on the battery casing (rear case)

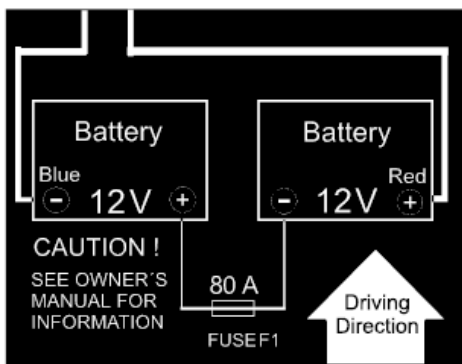

Battery connecting diagram, located inside the battery casing cover.

80A

Main fuse value information,
Located inside of the main fuse box

USING OTHER THAN
GEL BATTERIES IS FORBIDDEN

Using other than gel batteries is forbidden - warning
Located on the top of the battery cover (rear case).

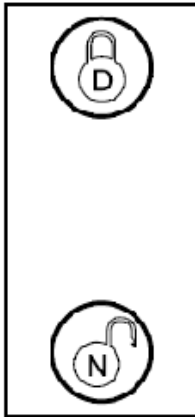

Freewheeling sing
D = breaks locked, the wheelchair can be driven
N = breaks released, the wheelchair can be towed
Located on front and rear axles



Attention, read the user manual
Located on the supporting frame, both sides from the seat



Do not push the wheelchair from the back rest



Risk of trapping hand / finger
These labels are located in the points where the danger exists.

2 EQUIPMENT AND THEIR USE



2.1 DRIVING CONTROLLER USE

The driving controller consists of a joystick and control panel. Under the driving controller you'll find the charger socket and the data transfer cable, which is connected to the control unit.

Joystick

The speed and direction of the wheelchair is adjusted by the joystick. The further you push the stick from the central position, the greater the drive speed. Releasing the joystick stops the wheelchair and applies the parking brakes. The joystick is also used for adjusting extra operations.

Joystick with a standard knob is suitable for most users. There are different alternatives to this knob or the knob can be tailor-made. Do not replace the knob with self-made parts, as they may cause dangerous situations.

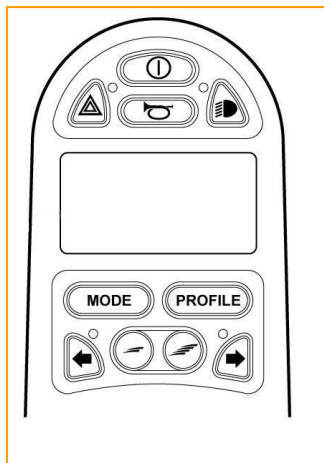
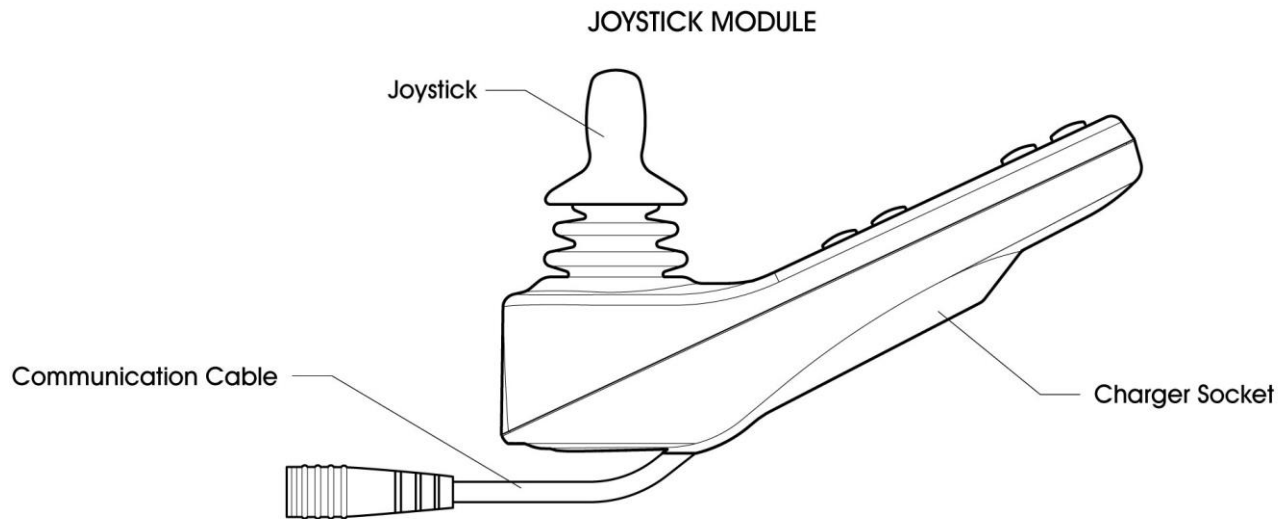

Control panel

The control panel contains push buttons and an LCD display. Operation of the push buttons is defined later in this chapter. When the driving controller unit is switched on, the LCD display is illuminated in the background and an icon of the currently used function is displayed. The symbols displayed are defined later in this chapter.

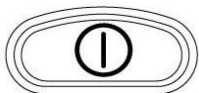

ON/OFF- button

With the ON/OFF button, the driving controller can be switched on and off. Do not use this switch to stop the wheelchair, except in an emergency.



Horn button

A sound signal sounds when the push button is pressed.

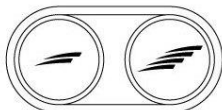

Speed buttons, Decrease/Increase

The maximum speed of the wheelchair can be increased by pressing the right push button and decreased by using the left push button. The choice of

maximum speed is seen on the display whilst choosing, provided it is programmed to be displayed. The maximum speed is the lowest when there is only one darkened column on the display and the greatest when all the columns on the display are darkened. When the joystick is moved forwards or backwards, the driving controller transfers to driving mode and applies the selected maximum speed. The maximum speed can also be adjusted while driving.

MODE button



With the MODE button you can navigate the adjustment menu. The available menus depend on the programming and the available operations of connected optional equipment.

Profile button



The desired user profile can be chosen with the profile button. The available profiles depend on the driving controller's programming and its equipment. The driving controller has pre-programmed profiles for indoor and outdoor driving. The maximum speed for the indoor driving profile has been adjusted lower than the speed in the outdoor driving profile.

Left turn indicator switch



By pushing the button, the wheelchair's left turn indicator lights are switched on. The indicator lights are switched off by pressing the push button again. When the indicator lights are on, the LED next to the push button will flash.

Right turn indicator switch



By pushing the button, the wheelchairs right turn indicator lights are switched on. The indicator lights are switched off by pressing the push button again. When the indicator lights are on, the LED next to the push button will flash.

Hazard warning switch



By pressing this push button, all the wheelchair's indicators will switch on. Pressing the push button again will switch the indicators off. When the warning indicators are on, the LEDs next to the push buttons for warning and direction indicators will flash.

Lights switch

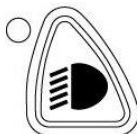

The drive lights are switched on and off. When the drive lights are switched on, the LED next to the push button will illuminate.

Charger socket

The charger socket is situated beneath the control unit. The socket is used for recharging the wheelchair's batteries or to lock the wheelchair. Only connecting the proper charger plug or lock key is permitted.

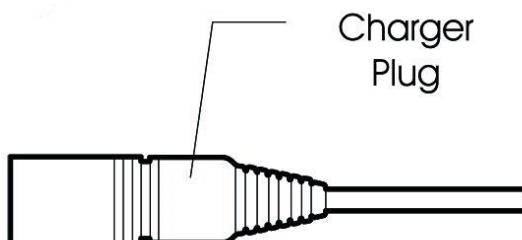

LCD DISPLAY

The state of the driving controller can be observed using the icons shown on the display. The icons shown and used on the display are the following.

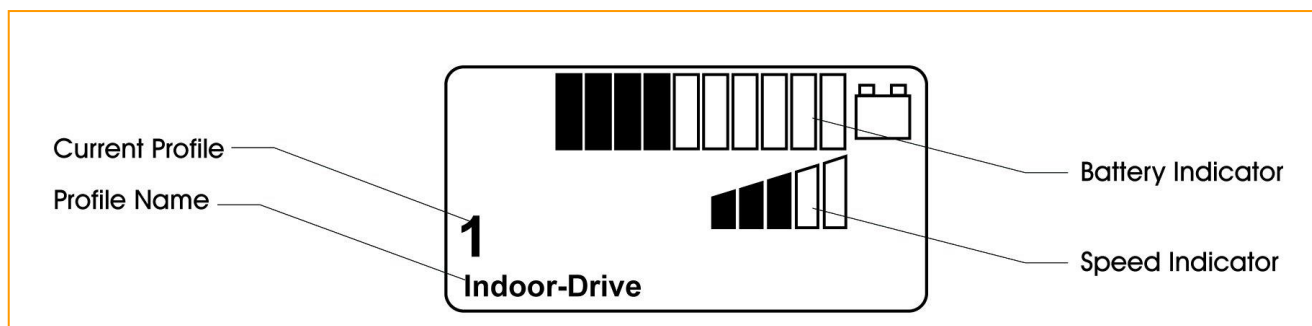

Battery indicator

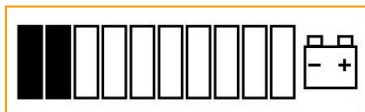

The picture shows the battery's charge level. High number of dark pillars indicates good charge level. If the icon flashes slowly, the battery charge level is low and they should be recharged immediately. When the batteries are recharging, the pillars will be darkened from left to right. The wheelchair cannot be used until the charger has been detached from the charger socket and the drive controller has been switched off and back on.

Speed indicator



This icon indicates the maximum speed setting. As the number of dark columns increases, so does the maximum speed. The maximum speed can be adjusted using the maximum speed adjusting switch.

Current profile

1

Indoor-Drive

The profile number and name indicates the profile currently in use.

In Focus



If the wheelchair has another driving controller such as a secondary Joystick Module or a Dual Attendant Module, the InFocus symbol is displayed. The icon indicates that the primary driving controller is not in control.

Restricted speed



If the speed of the wheelchair is limited because of a sharp turn, raised seat, the stand support or lift function etc., this symbol will be displayed. If the wheelchair is inhibited from driving, the symbol will flash.

Restart



When the Restart icon flashes on the display, the driving controller must be restarted.

Fault



When the system detects a fault, the Fault icon appears on the display. Refer to section "Electric malfunctions".

Motor temperature



This icon appears on the display when the system has automatically reduced power input to the motors to prevent overheating.

Control system temperature



This icon is shown on the display when the control system decreases power to protect itself from overheating.

Timer



This icon is shown when the control system is changing from one operation mode to another. The sand glass represents the time lapsing.

Balance and seat adjustment



The wheelchair's balance and seat can be adjusted by pressing the MODE button, whereupon this icon will be seen on the display. The seat part that is highlighted in the icon is currently adjustable. Adjustment is carried out by moving the joystick forwards and backwards. Different parts of the seat are chosen by moving the joystick to the left and right.

Temporarily displayed icons

In so far as the temporary icons are programmed to be seen, the icons below will be temporarily displayed by pressing the Speed or Profile buttons.

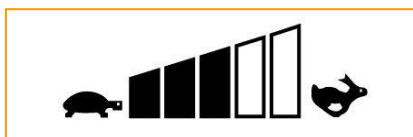

Profile 2
Outdoor-Drive

Locking



The Wheelchair can be locked using the locking key. To lock the wheelchair the driving controller has to be switched on. The locking key is inserted into the charger socket and immediately pulled out. The wheelchair is now locked and the display shows a lock icon.

To unlock, first switch the current on. Driving is however still not possible. Insert the locking key into the charger socket and immediately pull out. It is now possible to drive the wheelchair.

Troubleshooting

If the control system detects an error, a flashing exclamation mark (!) appears on the display together with a notice with the code of the possible fault. Refer to section "electric malfunctions".

2.2 BACK REST, HEAD SUPPORT, ARM REST AND FOOT REST ADJUSTMENTS

While making the adjustments, beware the possible flattening hazards. To get the best adjustment result, use the help of the attendant or service person.

BACK REST ADJUSTMENT

The wheelchair seat's back rest can be manually or electrically adjustable. While adjusting the back rest, assure that there will not be anything between the back rest and the battery casing cover, nor the back rest does not pressed against the battery casing cover.

MANUALLY ADJUSTABLE BACK REST

The back rest is manually adjusted by pushing the lever of gas spring on the left side of the seat and moving the angle of back rest to wanted position. Releasing the lever will lock the back rest.

ELECTRICALLY ADJUSTABLE BACK REST

An electrically adjustable back rest is adjusted with the driving controller. The adjustment mode is chosen by first pressing the MODE button and then moving the joystick to the left or right until the seat icon on the display only highlights the back rest section. The back rest is then adjusted by moving the joystick forwards and backwards. By pressing the MODE button, you can return to the drive mode.



HEAD SUPPORT ADJUSTMENT

In order to adjust the height of the head-rest, the plastic butterfly nut (1) at the back of the head-rest needs to be loosened until the head-rest can move freely on its attachment. Once the desired height has been achieved, the butterfly nut has to be tightened up again.

In order to adjust the depth of the head-rest, the plastic butterfly nut (2) behind the rod needs to be loosened until the head-rest can move freely on its attachment. Once the desired position has been achieved, the butterfly nut has to be tightened up again.

The padding of the head-rest is attached to the rod by a globe joint (3). The padding can be changed according to the user's head position.



ARM REST ADJUSTMENT

The width of the arm rest is adjusted by loosening the screw 1 and moving the arm rest sideways. When the suitable position has been found, retighten the screw. The maximum width is 60mm (picture below). The arm rest angle is adjusted by loosening the screws 2. When the suitable position has been found, retighten the screws.

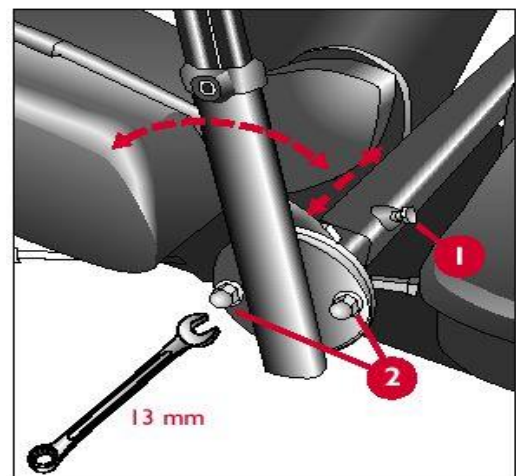
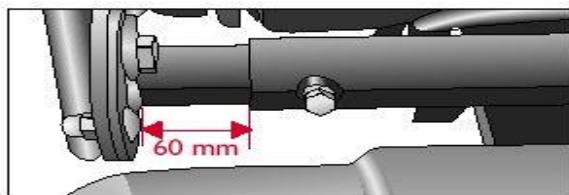

The arm rest height and angle are adjusted with a 5mm hexagonal key. Adjusting the height is performed by loosening the screw (A) and moving the arm rest up and down. When the height is suitable, retighten the screw.

For the adjustment of the arm rest angle, the support is raised to an upright position. The angle is adjusted by turning the screw (B), until the suitable position is found.

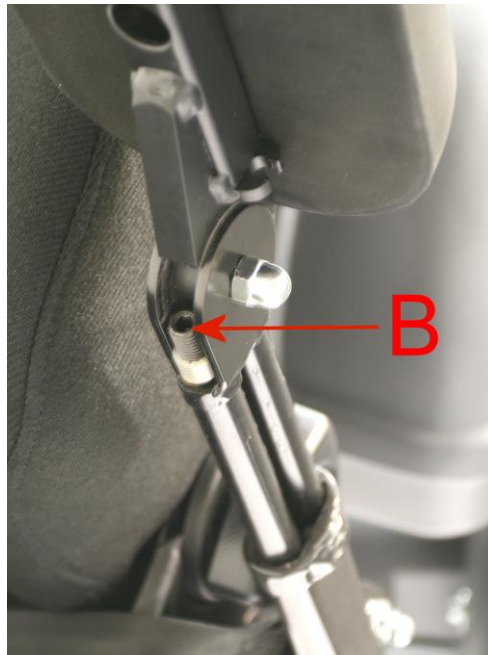

ADJUSTMENT OF A MANUALLY ADJUSTABLE FOOT REST

The distance of the leg support from the chair is adjusted by loosening the retaining knobs (1) in front part of the seat. When the correct distance is found, retighten the screws. The length is adjusted with a 5mm hexagonal key (2).

The foot rest angle (3) can be adjusted with a 13mm open spanner. The foot rest is adjusted by raising the lever (4), which releases the lock and the position can be adjusted. When the correct position has been found, release the lever. The foot support is now locked into this position.

It is necessary to observe the foot rest position when driving uphill or negotiating obstacles. Repeated striking of obstacles on the foot support may damage it.

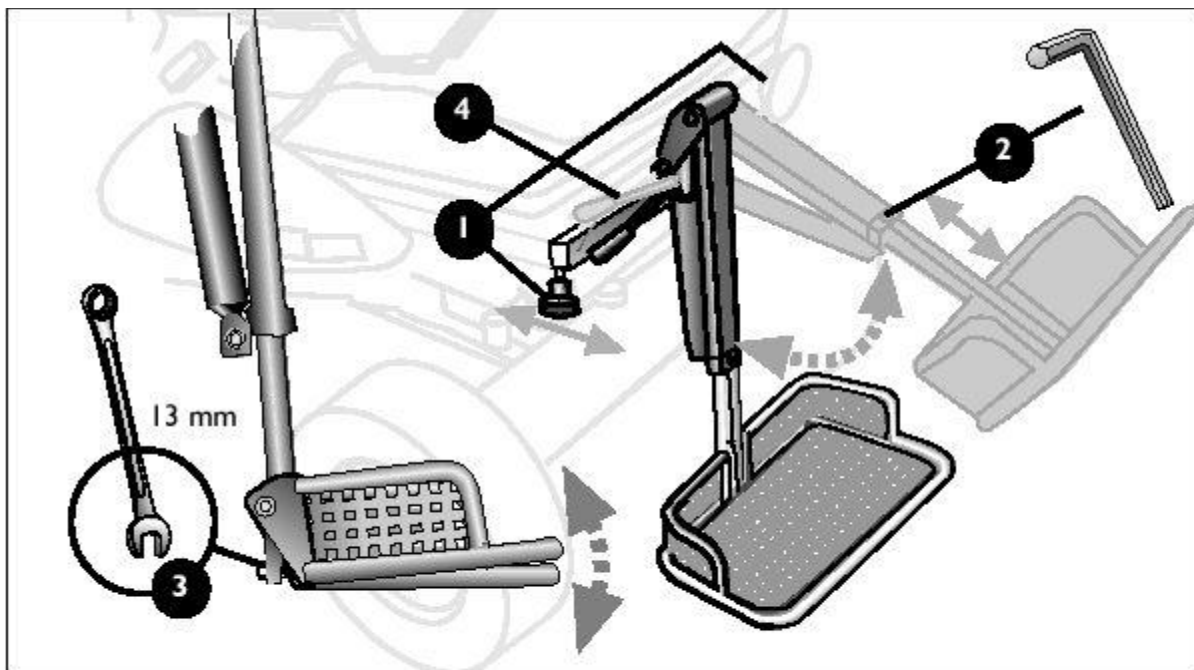

ADJUSTMENT OF AN ELECTRICALLY ADJUSTABLE FOOT REST WITH LENGHT COMPENSATION

Adjustment of distance, length and the foot rest angle is carried out similarly to the mechanical foot rest. The foot rest angle is adjusted by choosing foot rest adjustment on the driving controller's MODE menu. The operational mode is chosen when the displayed foot rest is highlighted. The foot rest is adjusted by moving the joystick forwards and backwards.

2.3 OTHER DEVICES AND SUPPLIES

SEAT BELT USE

The wheelchair is equipped with a safety belt. Its use is recommended. If the safety belt is not used, it should be prevented from dangling and getting entangled to the wheels.



TYRES

All four tyres of the wheelchair should be same size and profile. Because of tread profile they have a good grip on different surfaces.

The tyre pressure should be checked regularly. Measuring the tyre pressure is defined in section "wheelchair servicing".

BATTERIES

Service-free gel batteries are used as the wheelchair's standard batteries. Using other than gel batteries is forbidden due to a risk of electronic damage. The batteries are located in a case behind the back rest, which can be opened by turning the screw located at the centre of the lid. Instructions for removing and installing the batteries are in section "wheelchair servicing". Take note of the safety instructions regarding the batteries in section "safety recommendations". Used batteries should deliver to the proper recycle places.

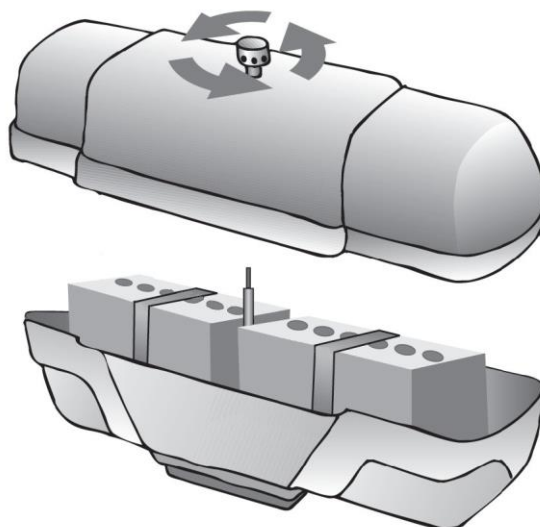

BATTERY RECHARGING

The wheelchair batteries are recharged by connecting the charger plug into the driving controller's charger socket. During recharging, the battery charge level is shown as an icon on the display and the wheelchair will not be possible to drive. Batteries must be recharged immediately, if the icon indicating the battery charge level shows only two full pillars. Follow the instructions supplied with the charger.

Use only the charger that has been supplied with the wheelchair.
Using incorrect chargers could damage the batteries, wheelchair or the charger itself.

FUSES

The wheelchair's main fuse (80A) is located between the batteries. If it is blown, the wheelchair will not have any electrical functions. The user must not change this fuse themselves; the wheelchair must be taken for service.



3 DRIVING THE WHEELCHAIR

MOUNTING TO AND FROM THE WHEELCHAIR

To make the mounting easier, the foot rest and arm rests can be lifted up as shown in the pictures below. Make sure not to damage the controller module and its cable.

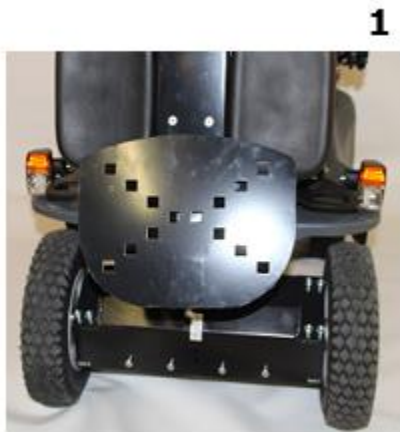

1. Folding the foot rest up.



2. Lift the arm rest up



3. Get your legs in front of the wheelchair



4. Be seated on the wheelchair



5. Adjust the angle of the footrest

Let the foot rest down and raise your feet on the rest front of the wheelchair.

To transfer from the wheelchair operate all actions reverse. To make transfer easier use for example sliding board on the seat and under the user and slide the user of the wheelchair.

DRIVE PRACTICE

Familiarize yourself with the wheelchair's performance capacity gradually and on different terrains, such as sand, snow, ice, off-road paths etc. to find the correct adjustments, speeds and ways of steering for different situations. Drive practice is also necessary for learning safe and flexible use of the wheelchair in different driving situations. It is especially important to learn the correct use of the balance adjustment system. Start practicing at a low maximum speed, when it is easier to control the wheelchair. As the wheelchair has four motors and four-wheel steering, its capacity is great and therefore utmost caution should be applied in the beginning.

The speed and direction of the wheelchair is adjusted by the joystick. By pushing the joystick forwards or backwards, the wheelchair moves to the direction determined by the current wheel position. If the wheels are turned so that the right side wheels are close to each other (picture 2), the wheelchair will move forward to the right when the joystick is pushed forward (Picture 3A) and backwards to the right by pulling the joystick backwards (Picture 3b).

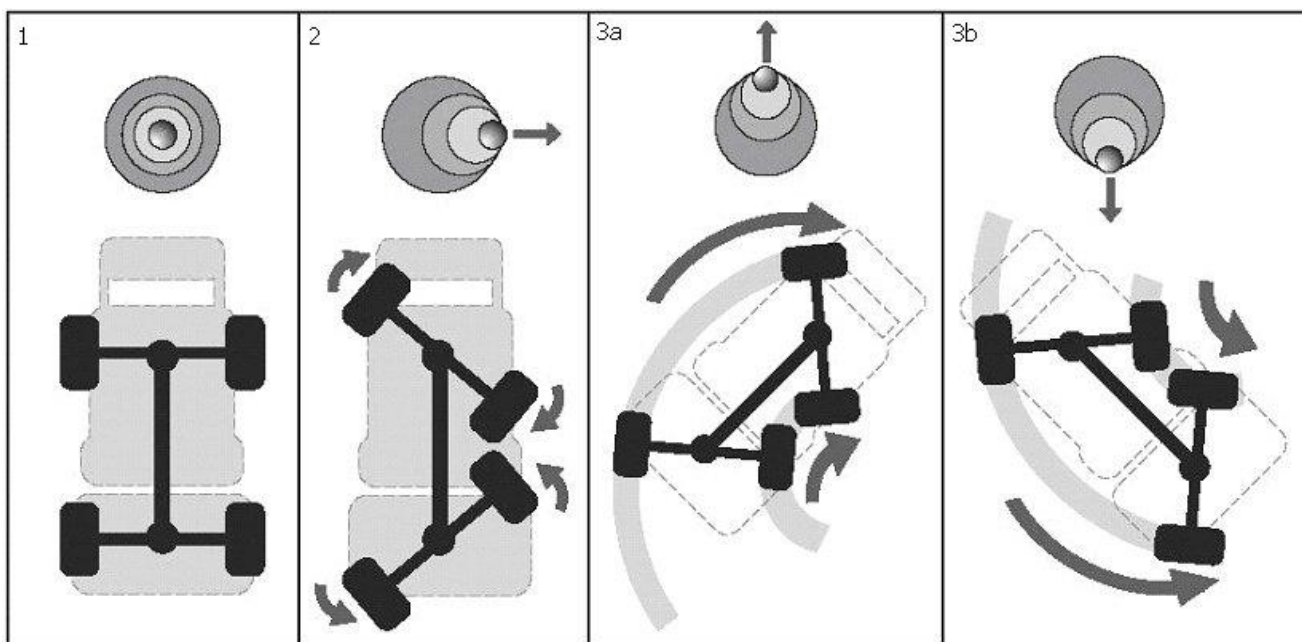

The driving direction is corrected by moving the joystick sideways. After this, keep pushing the joystick straight forward and make only small sideways movements until the correct drive direction is found. Avoid extreme movements and start driving slowly to find the correct feel. If the wheelchair moves in an undesired way, release the joystick. This stops the wheelchair in all situations. In emergency situations switch the driving controller off. When you have learned how to use the wheelchair on a level surface, you can start practicing how to negotiate obstacles and hills, where it is essential to master the balance adjustment system.

BALANCE ADJUSTMENT

The balance adjustment system means that the seat can be moved in relation to the frame. In addition, when the seat is moved backwards, it starts to tilt at a certain stage.

For adjusting the balance, the driving controller must be set to the balance adjustment mode. This mode is accessed by pressing the MODE button, until the display shows the seat parts (back rest and seat plate) darkened. The balance is adjusted by moving the joystick forwards and backwards. When the joystick is pushed forwards, the seat moves forward in relation to the frame.

In the drive position for even ground the seat starts to tilt backwards while the balance is shifted backwards. The recommended balance positions for driving uphill, on even ground and downhill are represented in the pictures below.

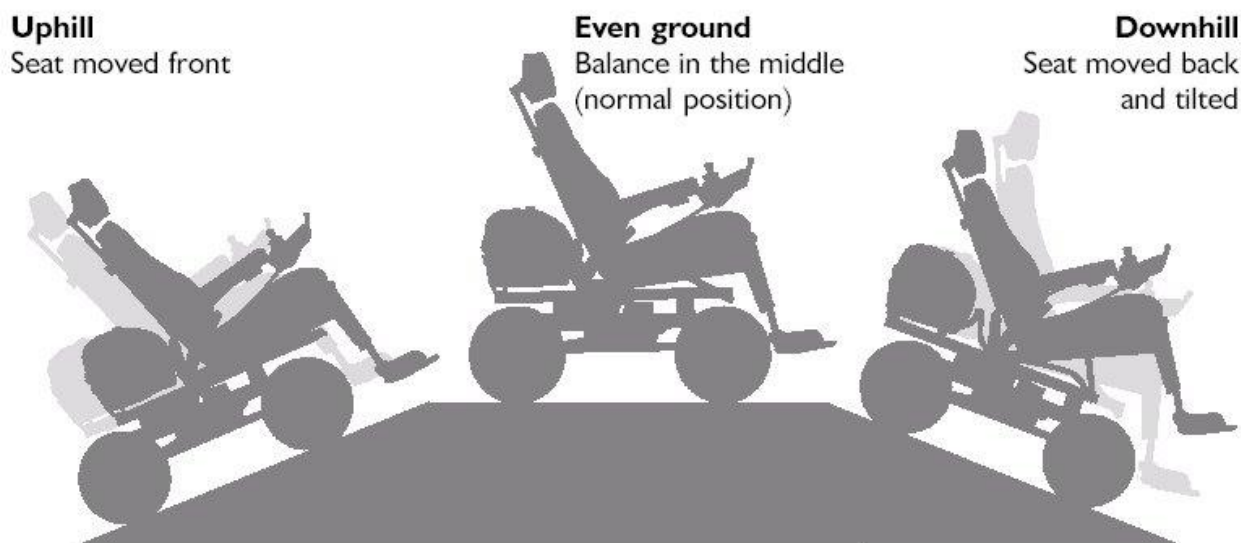

Avoid driving uphill if the seat is moved backwards. Do not drive downhill, if the seat is moved forwards. These positions are incorrect and can be dangerous.

Adjust the maximum speed lower when driving up or downhill and when crossing high obstacles.

In case of a fault in the balance adjustment actuator, in its connecting cable or in the joystick module, the seat is left in the position in which it is when the fault occurs. This may lead to a situation in which the user has to drive with an incorrect balance adjustment, which in turn may lead to fall of the wheelchair.

CLIMBING OBSTACLES

Approach the step slightly sideways so that the wheelchair is able to mount the step one wheel at a time. Move the balance position backwards and raise the foot rest so that it doesn't hit the step. Drive the wheelchair's front wheels onto the step.

1



2



Move the balance forwards so that wheelchair's rear part becomes lighter and drive the entire wheelchair onto the step. Finally, move the balance to even ground position. The same driving method can be used to overcome greater obstacles.

3



4



4 FREEWHEELING

Malfunctions, transport etc. may demand that the wheelchair should be towed. To make this possible the brake releases must be switched on. This can be done by turning the levers (2 pcs) in both axles towards the outside of the wheelchair. When the parking brakes are released, the wheelchair cannot be driven, and therefore controlling it is difficult and moving it on a sloping surface is dangerous. During the towing the driving controller must be switched off. When freewheeling, notice that it is forbidden to push the wheelchair.

5 TRANSPORTATION AND PACKAGING OF THE WHEELCHAIR

Transferring the wheelchair into the vehicle must be done with ramps or hoister that is located in vehicle.

The wheelchair has been equipped with 4 vehicle tie down brackets conforming ISO 7176-19 standard. Tie down brackets are located in front and rear part of support frame on the both sides of wheelchair. Use all 4 fixing points to attach wheelchair to vehicle with straps. During transportation make sure that brake levers are in driving position and wheelchair is powered off. Make sure that joystick is protected so the wheelchair doesn't accidentally turn power on.

For transporting the wheelchair on an aeroplane, a ship, a train or other means of transport, contact the organiser of transportation to receive transport instructions.



If the wheelchair needs to be packed, drive the wheelchair on the pallet. Notice that the user cannot be in the wheelchair while driving it on the pallet. Wheelchair should be attached to the pallet like it is attached for the transportation. Footrest should be bent down and foot plate up. Head support is good to be adjusted in the lowest position. If necessary the head support can be removed and attached on the seat. It is recommended to cover the wheelchair with cardboard box or wooden crate.

The wheelchair can be moved for example to truck by driving it or if the wheelchair is on the pallet, by loading pump.

6 WHEELCHAIR SERVICING

After driving under moisture circumstances, take care of drying the wheelchair for example by storing it in a warm space. Do not leave the wheelchair outside or in cold and moisture spaces. Not following these instructions might damage the wheelchair.

By servicing the wheelchair regularly, you ensure the functioning and safety of your wheelchair. A well serviced wheelchair is a long-term aid. Part of the servicing can be performed by users themselves (these operations are mentioned below). However, the more demanding service operations (such as electrical malfunctions, driving motors, actuators, frame parts, seat parts, foot and arm rests, changing the tyres and other technical problems) can only be done by a qualified technician in order to maintain the warranty.

The manufacturer intends the wheelchair to be serviced/maintained by qualified technician (either distributor, service agent or the manufacturer) at least once a year.

Service card of the wheelchair is in the last pages of the Owner's manual. Please take care of that the Owner's manual goes with the wheelchair to the service. When it is a time to service the wheelchair, please contact to your FOUR X distributor.

Following routine operations the manufacturer intends the user to be responsible:

- daily inspections
- weekly inspections
- cleaning the wheelchair

If necessary the user could ask assistant or some other person for help.

DAILY INSPECTIONS

Before beginning the drive check the general condition of the wheelchair visually. When the driving controller is switched off, check that the joystick is not bent or damaged and that it returns to the middle when released. Check that all the connectors are in place and undamaged and the cables are in good condition. Check that the thin protective rubber around the steering stick is not damaged. Handle the protective rubber with care. Make sure that the control module is well attached to the wheel chair. Do not over tighten the screws.

WEEKLY INSPECTIONS

Brake tests are made on an even floor, with at least one meter of free space around the wheelchair. Switch on the control system. Check that the light bar is lit in one second or flashes slowly. Push the joystick slowly forwards until you hear the parking brakes working. The wheelchair may start moving. Release the joystick immediately, and you should be able to hear the sound of the brakes operating in a few seconds. Repeat this test three times also by pushing the joystick backwards, and to the left and right.

Check the operation of the lights, turn indicators and the balance adjustment. If the wheelchair has an electrically adjustable back and/or foot rest, also check their operation. In problem situations, do not use the wheelchair, but contact service.

CLEANING AND DISINFECTION THE WHEELCHAIR

Clean the wheelchair with a moist soft fabric and diluted cleaning fluid. Avoid the use of undiluted cleaning fluids as these may damage the plastic and fabric parts of the wheelchair. Follow the recommendations set by the cleaning fluid manufacturers regarding the different materials. In the event of the control module becoming dirty, it must be cleaned immediately. Pressure cleaning or use of a shower is forbidden, as the wheelchair has electric units, which will be damage when wet.

The wheelchair can be disinfected totally for example by spraying the disinfectant on the wheelchair. The electronics of the wheelchair are in the battery box so keep the battery box closed during the disinfection. While disinfecting, notice the wheelchair's texture surfaces (seat, supports) which should be disinfected with the suitable methods.

Following operations the user is able to do with help of assistant or some other person:

- measuring the tyre air pressure
- changing tyres
- disconnecting the batteries
- installing the batteries
- changing the lamp

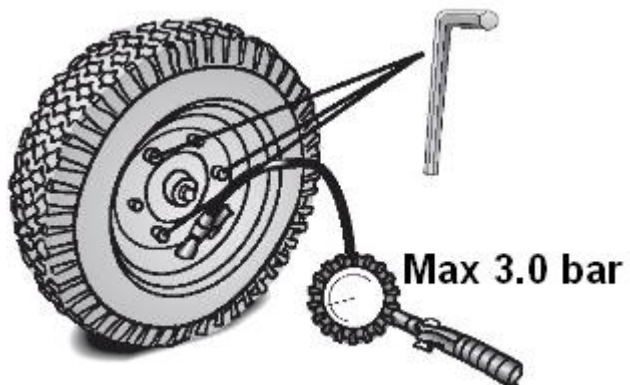

MEASURING THE TYRE AIR PRESSURE

The suitable air pressure in the tyre is approx. 1.5 bar-2.5 bar. Air pressure decrease under 1.2 bar and filling over 3.0 bar is not advised. This increases the wear of tyres, decreases grip and causes extra friction, which shortens the driving distance.

TYRE EXCHANGE

The rim is attached to the motors hub with hexagonal socket screws, always use correct size tools. Support the axle so that the tyre is off the ground. After that **release the air pressure from the tyre**. When you have done this open the screws and take of the tyre. Both halves of the rim are attached to each other with screws, which you are not allowed to open until you have released the air pressure.

Assembling the wheel with tyre.

Install inner tube into the outer tyre and install this packet onto the rim half. Attach both rim halves together with screws. Pay attention that the inner tube does not squeeze between the rim halves. Now fill the tyre a little bit (0.5bar) to get the inner tube straight. After this install the tyre onto the motors hub with coach screws. When tyre is attached to the motor, fill up the tyre (approx. 3bar is reasonable). After this remove lifting equipment and the chair is ready to drive again.

DISCONNECTING THE BATTERIES

Detach the cables (- and +) and the main fuse from the batteries using 10mm open ended spanner. Remove the 2 battery securing brackets by unscrewing the M8 nylock locking nuts.

Lift the batteries from the casing.

Use only gel batteries.

Suitable gel batteries for Four X wheelchair the user can get from the Four X distributor.

Notice: If you have old or possibly damaged gel batteries, please handle them very carefully and not with bare hands, because there might be a risk of leaking.

Deliver the batteries to the hazardous waste disposal point or your Four X service agent.

INSTALLING THE BATTERIES

Install the batteries in the casing (+ pole on the wheelchair's right side)

ATTENTION! Do not place metal/other conductive objects (like tools) on batteries while battery terminals are uncovered. Metal object touching + and – terminals will make a short circuit and potentially cause damage to batteries, electronics and serious safety risk to user!

Tighten the connection straps.

Install the cables red+, black-.

Install the main fuse case.

Check that all the connections are tight.

Pole grease can be used to prevent oxidisation.

Set the battery container cover in place and tighten the knob screw.

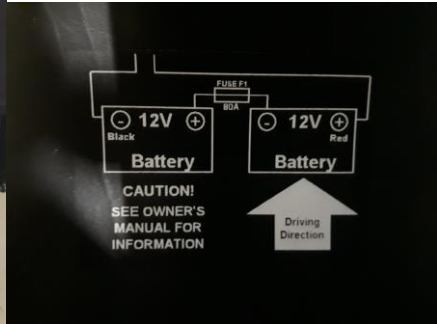
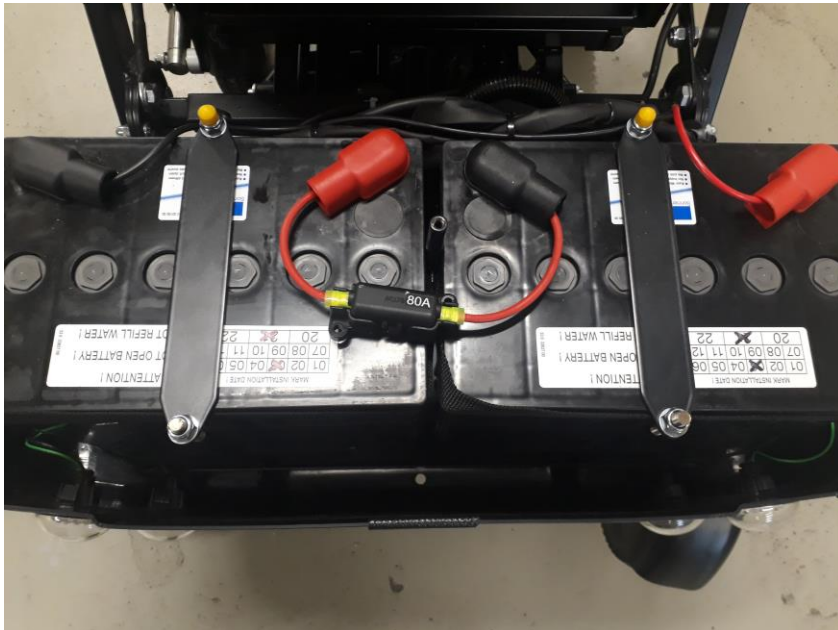

DRIVING LIGHTS AND INDICATORS

Four X DL wheelchair is equipped with maintenance free LED driving lights and indicators.

SPARE PART INFORMATION

Wheelchair spare parts should be changed by the wheel chair manufacturer, distributor or trained service agent, NOT THE USER. If there are parts to be changed, the user should contact immediately to the Four X distributor. Please find manufacturer information/your distributor information from the cover page of Owner's manual, or manufacturer's webpage www.moventuras.com.

ELECTRIC MALFUNCTION

The driving controller indicates electric malfunctions by flashing an exclamation mark (!) on the display. For safety reasons, driving with the wheelchair is prevented during the malfunction. Typical electric malfunctions are caused by the connectors or the batteries. The most typical reasons for malfunctions are listed below.

-The driving controller has switched on to the power save mode. This happens automatically, when the driving controller has not been used for a period of time. The time depends on the programming of the driving controller. To re-start, switch the driving controller on and off.

-The batteries are weak, when battery charge level icon flashes slowly. Batteries should be recharged as soon as possible.

-The batteries are recharging. Check that the charger plug is not connected to the drive control.

-The connectors of the driving controller system or the battery have become loose. Switch the driving controller off and check that all connectors are in place.

-The brake levers are on N position. Turn the brake levers to D position. Instructions can be found in section "Freewheeling".

Switch the driving controller on and try to drive the wheelchair. If the exclamation mark continues to flash on the display, switch the driving controller off. Do not use the wheelchair and contact service.

PROGRAMMING

The driving properties of the wheelchair can be reprogrammed. In delivery, the wheelchair's driving properties are set so that they are suitable for most users. By reprogramming you can change the joystick reaction time, time settings for the power save mode, wheel turning speed etc. If you wish to change the drive properties of your wheelchair, contact the wheelchair seller or manufacturer.

RE-USE AND RECYCLING

Wheelchair is suitable and intended for re-use. For re-use wheelchair is serviced completely. In the wheelchair there are several different adjustment possibilities. For new user the necessary changes and adjustments are done to the wheelchair, for example to the seat, to the arm- and footrests and to the control system.

All the parts that are removed or replaced should be recycled in proper way. There are own recycling points for metal (metal parts), plastic (fenders, covers), rubber (tyres, arm rests, bushings), hazardous waste (gas springs, gel batteries).

Other components, for example driving motors, actuators, electric components, seats, should be deliver to the distributor or the manufacturer and they will take care of the recycling.

7 WHEELCHAIR STORAGE

Protect the wheelchair from heat and moisture during storage. The wheelchair goes into the smaller space by folding the back rest, the arm rests and the foot rest.

Disconnect the batteries and store them fully recharged in a dry and cool place. During the storage the batteries should be recharged at least once every six months.

8 USE OF THE WHEELCHAIR AS A SEAT IN A VEHICLE

This power wheelchair complies with the requirements of ISO 7176-19:2001 and may be used as a vehicle seat in connection with an anchoring system that has been checked and approved in accordance with ISO 10542. The wheelchair has undergone a crash test in which it was anchored in the transporting vehicle's direction of travel. Other configurations were not tested. The crash test dummy was secured using pelvic and upper body safety belts. Both types of safety belt should be used in order to minimize the risk of injuries to head or upper body. It is imperative that the wheelchair is inspected by an authorized dealer before being used again after being involved in a crash. Alterations to the wheelchair anchoring points may not be carried out without the manufacturer's permission.

Caution: There is a danger of injury if the wheelchair is not properly secured during use as a vehicle seat!

- If possible, the user should always leave the wheelchair to use a vehicle seat and the safety belts provided with the vehicle.
 - The wheelchair should always be anchored facing in the transport vehicle's intended direction of travel.
 - The wheelchair must always be secured in accordance with the wheelchair and anchoring system manufacturers' operating manual.
 - Always remove and secure any accessory parts fixed to the wheelchair such as chin controls or tables.
 - If your wheelchair is equipped with an angle adjustable backrest, then it must be placed in an upright position.
 - Fully lower elevated leg rests, if fitted.
 - Fully lower the seat lifter, if fitted.
 - Always completely lower height-adjustable leg rests, if fitted
- WARNING: Danger of injury exists if a power wheelchair that is not equipped with leak-proof batteries is transported in a vehicle!***
- Only ever use leak-proof batteries!

CAUTION: There is danger of injury, if the batteries are not properly secured!

- Secure the battery belt with the safety

How the wheelchair is anchored in a vehicle for use as a vehicle seat

The power wheelchair is fitted with four anchoring points, which are labeled with the symbol shown on the right. Snap hooks or belt loops can be used for fixation.



- Secure the wheelchair at the front (1) and at the rear (2) with the anchoring system belts

Front

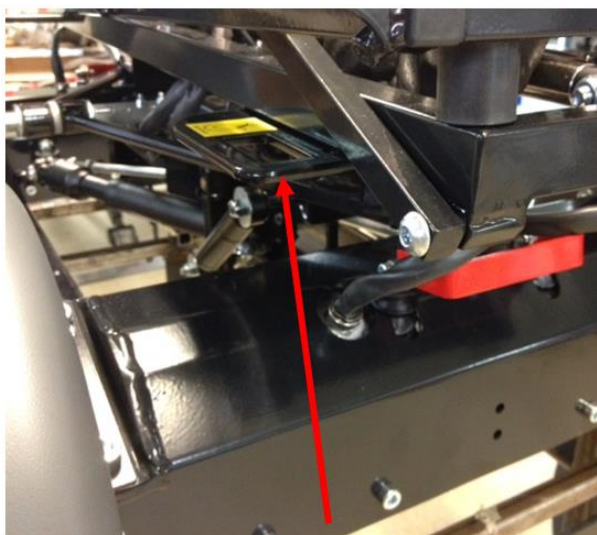

Rear (only left-hand side visible in picture)

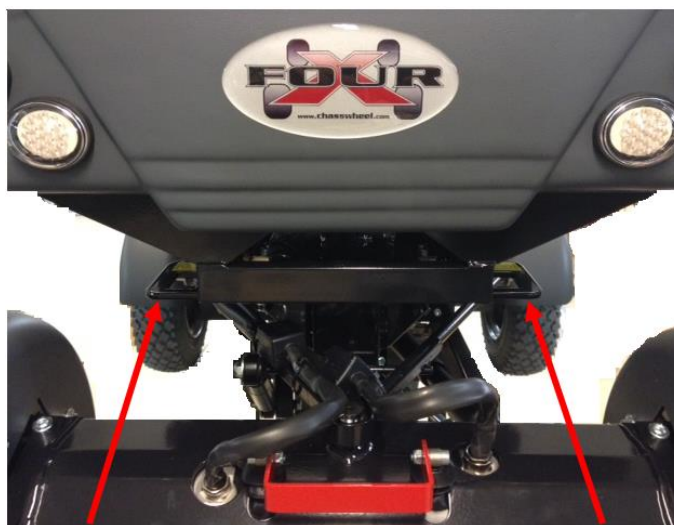

How the user is secured within the wheelchair

CAUTION: There is a danger of injury if the user is not properly secured within the wheelchair!

- Even if the wheelchair is fitted with a postural belt, this is no substitute for a proper safety belt which complies with ISO 10542 in the transport vehicle. Always use the safety belt installed in the transport vehicle.
- Safety belts must be in contact with the user's body. They must not be held at a distance from the user's body using parts of the wheelchair such as armrests or wheels.
- Safety belts must be pulled as tightly as possible without causing the user discomfort.
- Safety belts must not be positioned while twisted.
- Ensure that the third seatbelt anchorage point is not fixed directly to the vehicle floor, but to one of the vehicle uprights.
- A headrest must be installed! The headrest optionally supplied for this mobility device by Moventuras is perfectly suitable for use during transport.

- The headrest must be adjusted to the user's ear height.

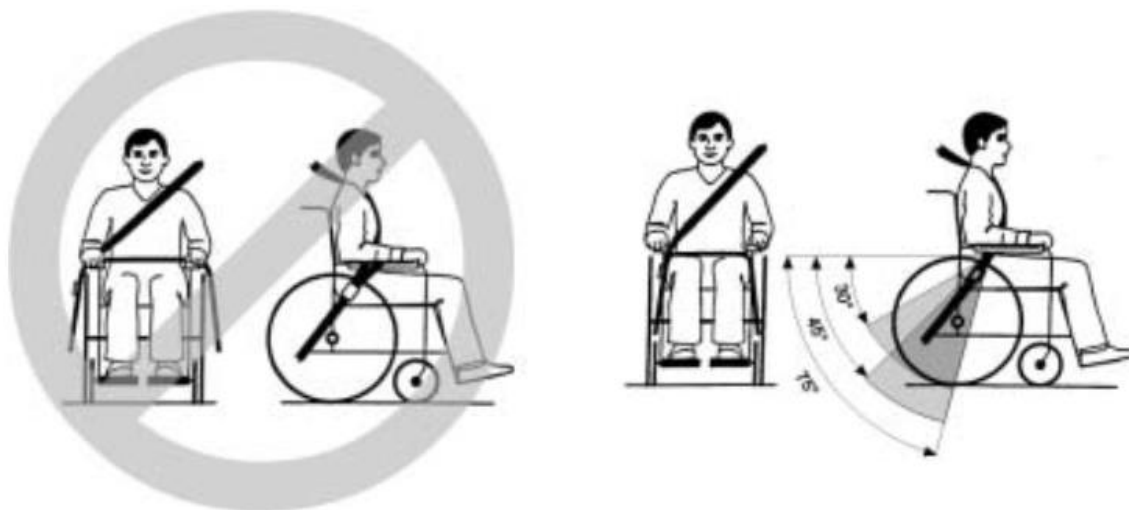

Seat belts may not be held at a distance from the user's body using parts of the wheelchair such as armrests or wheels.

The pelvic belt should be positioned in the area between the user's pelvis and thighs so that it is unobstructed and not too loose. The ideal angle of the pelvic belt to the horizontal is between 45° and 75°. The maximum permissible angle is between 30° and 75°. The angle should never be less than 30°!

The safety belt installed in the transporting vehicle should be applied as shown in the illustration at right.

- 1) Centre line of the body
- 2) Centre of the sternum

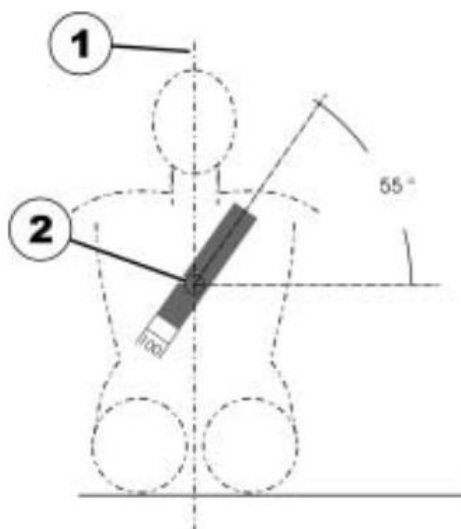

9 TECHNICAL INFORMATION CW4 FOUR X DL

Wheelchair classification	C
Maximum allowable user weight	125 kg
Driving speed (depending on wheel size)	approx. 10 km/h
Driving distance, depending on drive conditions and battery gauge	approx. 35 km
Minimum ground clearance (depending on wheel size)	about 110 mm
Obstacle negotiation ability (depending on wheel size)	110 mm
Maximum obstacle negotiation ability	130 mm
Slope climbing capacity	20°
Maximum safe slope	10°
Turning radius	1150 mm
Turn around width	1700 mm
Operating temperature	- 25°C - + 40°C
Charger (standard)	8 A
Maximum permitted charging current	12 A
Total weight of the wheelchair (depending on model)	120-149 kg
Seat with standard size cushions	
-width	440 mm
-seating depth depending on cushion sizes	390 - 510 mm
-backrest height	682 mm
-seating height (depending on wheel chair model and seat cushion)	570 mm – 630 mm
Overall dimensions of the wheelchair (footrest on transportation position and headrest removed)	
-width	695 mm
-length (footrest down, footplate up)	1250 mm
-height (varies depending on the seat and backrest position)	700 - 850 mm
Tyres (both rear and front tyres)	
Tyre pressure, depending on the model	3.00 - 8" or 4.10/3.50-6"
Electric system	1,5 - 3,0 bar (150 kPa - 300 kPa)
Main fuse	24V
Driving controller	80A
Driving motors (4 x 250 W)	R-Net system /PG Driving Technology
Brakes	1000W
Standard battery 73 Ah	4 pcs connected with 2 brake levers
Gravity point adjustment/TILT actuator	2 pcs x 12V
Frame	Linak LA28
Shock absorption	steel, stove enamelled powder paint
	2 shock absorbers,
	1 steering attenuator
	1 leaf spring

10 SERVICE CARD OF FOUR X DL WHEELCHAIR

Frame no.: _____

Annual maintenance Yes ___ No ___

Additional maintenance (if needed):

Notices (if needed):

Maintenance done by _____

Date and place _____

Annual maintenance Yes ___ No ___

Additional maintenance (if needed):

Notices (if needed):

Maintenance done by _____

Date and place _____

Frame no.: _____

Annual maintenance Yes ___ No ___

Additional maintenance (if needed):

Notices (if needed):

Maintenance done by _____
Date and place _____

Annual maintenance Yes ___ No ___

Additional maintenance (if needed):

Notices (if needed):

Maintenance done by _____
Date and place _____

Frame no.: _____

Annual maintenance Yes ___ No ___

Additional maintenance (if needed):

Notices (if needed):

Maintenance done by _____

Date and place _____

Annual maintenance Yes ___ No ___

Additional maintenance (if needed):

Notices (if needed):

Maintenance done by _____

Date and place _____

Frame no.: _____

Annual maintenance Yes __ No __

Additional maintenance (if needed):

Notices (if needed):

Maintenance done by _____

Date and place _____

Annual maintenance Yes __ No __

Additional maintenance (if needed):

Notices (if needed):

Maintenance done by _____

Date and place _____

Frame no.: _____

Annual maintenance Yes ___ No ___

Additional maintenance (if needed):

Notices (if needed):

Maintenance done by _____

Date and place _____

Annual maintenance Yes ___ No ___

Additional maintenance (if needed):

Notices (if needed):

Maintenance done by _____

Date and place _____

FOUR X DL SSS



STAND SUPPORT SYSTEM

Contents

1 SAFETY RECOMMENDATIONS

Safe driving

2 EQUIPMENT AND THEIR USE

Safety belt use

Knee support use

Electric adjustment length compensation for the foot support

Centre of gravity adjustment

Raising of the seat section

Folding of the upper part of the back

Head support adjustment

Lift operation

180° tilting

Operation of the upright position raiser

3 TECHNICAL INFORMATION ON THE STAND SUPPORT SYSTEM

1 SAFETY RECOMMENDATIONS

THIS USER MANUAL IS FOR USE, ONLY TOGETHER WITH THE OWNERS HANDBOOK! THIS SECTION EXPLAINS ONLY CONNECTED MATTERS CONCERNING USE OF THE STAND SUPPORT SYSTEM.

SAFE DRIVING

Do not use the Stand Support System, if you suspect that its use is not safe. For safety of use, the condition of the appliance, environmental conditions and the user's ability to control the machine must be observed.

On an inclined surface, driving in the erect position is absolutely forbidden due to the dangers of overturning.

Do not use the appliance if you suspect that some part may be broken, but deliver the appliance directly for servicing.

Before raising to the upright position, ensure that the safety accessories are properly attached.

The appliance is installed with a speed limiter, which halves the maximum speed automatically when the upright position raiser operation is used.

If you suspect that the limiter is not operating properly, do not use the Stand Support System, but contact service.

When inclining the back backwards in the sitting position or lowering to the lying position, take care that the upright position raiser appliance does not create pressure on the battery compartment. This can cause the seat's spindle motor or battery compartment to be damaged.

When using the Stand Support System, ensure that the foot support can move freely.

In a case that the foot support catches on the floor, an obstacle or an axis, stop operations and adjust the various sections of the seat until the foot support is freed.

The foot support is generally released by adjusting the seat downwards or by adjusting the centre of gravity backwards. An obstruction to the foot support may result in breakage of the spindle motor used in the foot support adjustment.

Do not push the wheelchair. Use the drawstrings for transferring the wheelchair.

2 EQUIPMENT AND THEIR USE

SAFETY BELT USE

The Stand Support System is equipped with a 4 point safety belt. The use of this is always recommended whilst sitting in the wheelchair and must absolutely be used whilst using the Stand Support System.

The safety belt must always be adjusted as suitable for the user.

KNEE SUPPORT USE

Included in the Stand Support System is a knee support, which is to always be used during the operation of the Stand Support System.

The knee support is attached by connecting the triangular hooks that are at the end of the knee support strap, to notches that are located on the front corners of the chair. Ensure that the hooks are attached behind the slide preventer. The knee support is adjusted by a sliding adjustment band. The adjustment band has velcro fastening. The knee support is adjusted correctly when it is snapped underneath the kneecap. A loosely attached knee support does not give enough support whilst in the erect position.

SEAT OPERATION ADJUSTMENT

The wheelchair seat is adjusted by pressing the MODE-button, whereupon the picture of the adjustment appears on the screen. The seat part, which is seen darkened in the picture, is at that moment adjusting. Adjustment happens by moving the guidance stick forwards and backwards. Choosing the different parts of the seat occurs by moving the guidance stick to the right and left sides by quick movements. By pressing the MODE button again, you can get back to the drive situation.

FOOT SUPPORT ADJUSTMENT

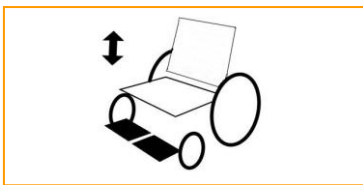

The angle of the foot support is adjusted by selecting the foot support adjustment from the MODE selection of the drive control. The operational state is chosen when the foot support on the display is visibly darkened. The foot support is adjusted by moving the guidance stick forwards and backwards.

FOCUS OF GRAVITY ADJUSTMENT



The centre of gravity can be adjusted when the seat part and the horizontal arrow are visibly darkened. The centre of gravity adjustment is used for driving in the sitting position up and downhill and as an aid during the Stand Support System.

RAISING THE SEAT SECTIONS



The height of the seat can be adjusted when; the seat section and the vertical arrow are visibly darkened. Adjustment of the seat height is good to use as an aid in adjusting the centre of gravity. When the centre of gravity is adjusted possibly back, the seat is raised higher.

ADJUSTMENT OF THE BACK SECTIONS

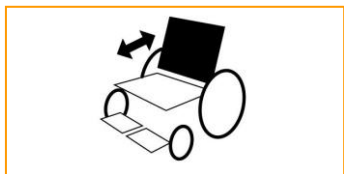

The position of the backs can be adjusted, when the backs and the horizontal arrow are visibly darkened

FOLDING OF THE UPPER SECTION OF THE BACK

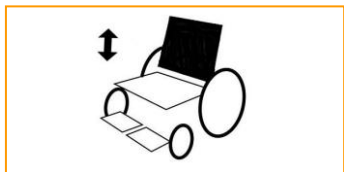

The back part is possible to be folded when the backs upper part is folded backwards through different operations. Adjustment of the upper part of the back is possible when, the backs and the vertical arrow are visibly darkened.

STAND SUPPORT SYSTEM



When all the seat parts are visibly darkened, the seat is raised to the users sitting position, when the control stick is pushed forwards.

If one of the spindle motors, which is required for the Stand Support System is broken, this operation cannot be used

3 TECHNICAL INFORMATION ON THE STAND SUPPORT SYSTEM

Greatest safety use gradient
Seat actuator
Back rest actuator
Foot rest actuator

5°
MBL NAU001-F
MBL NAQ002-F
Linak LA20

FOUR X DL SEAT RISER



SEAT RISER SYSTEM

Contents

1 SAFETY RECOMMENDATIONS

Safe driving

2 EQUIPMENT AND THEIR USE

Safety belt use

Seat functions adjustment

Electric adjustment length compensation for the foot support

Centre of gravity adjustment

Raising of the seat section

Backrest adjustment

3 TECHNICAL INFORMATION ON THE SEAT RISER SYSTEM

1 SAFETY RECOMMENDATIONS

THIS USER MANUAL IS FOR USE, ONLY TOGETHER WITH THE OWNERS HANDBOOK! THIS SECTION EXPLAINS ONLY CONNECTED MATTERS CONCERNING USE OF THE SET RISER SYSTEM.

SAFE DRIVING

Do not use the Seat Riser System, if you suspect that its use is not safe. For safety of use, the condition of the appliance, environmental conditions and the user's ability to control the machine must be observed.

On an inclined surface, driving in the erect position is absolutely forbidden due to the dangers of overturning.

Do not use the appliance if you suspect that some part may be broken, but deliver the appliance directly for servicing.

Before raising the lift, ensure that the safety accessories are properly attached.

The appliance is installed with a speed limiter, which limits the maximum speed automatically when the seat riser operation is used.

If you suspect that the limiter is not operating properly, do not use the Seat Riser System, but contact service.

When inclining the back backwards in the sitting position, take care that the back rest does not create pressure on the battery compartment. This can cause the seat's spindle motor or battery compartment to be damaged.

When using the Seat Rises System, ensure that the foot support can move freely.

In a case that the foot support catches on the floor, an obstacle or an axis, stop operations and adjust the various sections of the seat until the foot support is freed.

Do not push the wheelchair. Use the drawstrings for transferring the wheelchair.

2 EQUIPMENT AND THEIR USE

SAFETY BELT USE

The Seat Riser System is equipped with a safety belt. The use of this is always recommended whilst sitting in the wheelchair and must absolutely be used whilst using the Seat Riser System.

The safety belt must always be adjusted as suitable for the user.

SEAT OPERATION ADJUSTMENT

The wheelchair seat is adjusted by pressing the MODE-button, whereupon the picture of the adjustment appears on the screen. The seat part, which is seen darkened in the picture, is at that moment adjusting. Adjustment happens by moving the guidance stick forwards and backwards. Choosing the different parts of the seat occurs by moving the guidance stick to the right and left sides by quick movements. By pressing the MODE button again, you can get back to the drive situation.

FOOT SUPPORT ADJUSTMENT

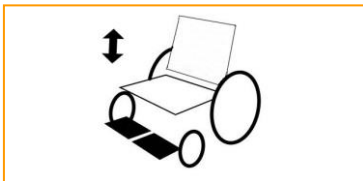

The angle of the foot support is adjusted by selecting the foot support adjustment from the MODE selection of the drive control. The operational state is chosen when the foot support on the display is visibly darkened. The foot support is adjusted by moving the guidance stick forwards and backwards.

FOCUS OF GRAVITY ADJUSTMENT



The centre of gravity can be adjusted when the seat part and the horizontal arrow are visibility darkened. The centre of gravity adjustment is used for driving in the sitting position up and downhill and as an aid during the Stand Support System. When the seat is risen with seat riser operation, you are not able to adjust the gravity point backwards.

RAISING THE SEAT SECTIONS



The height of the seat can be adjusted when; the seat section and the vertical arrow are visibly darkened.

ADJUSTMENT OF THE BACK SECTIONS

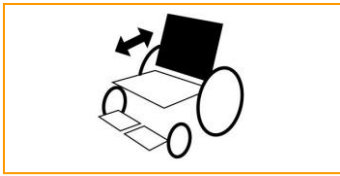

The position of the backs can be adjusted, when the backs and the horizontal arrow are visibly darkened. When the seat is risen with seat riser operation, you are not able to adjust the back rest backwards.

3 TECHNICAL INFORMATION ON THE SEAT RISER SYSTEM

Greatest safety use gradient
Seat riser unit
Seat riser actuator

5°
NLT0300C-0
NAQ101-D1